

Q.1(a) Test whether $P(s) = s^5 + 12s^4 + 45s^3 + 60s^2 + 44s + 48$ is Hurwitz [5]
 polynomial.

(A) $P(s) = s^5 + 12s^4 + 45s^3 + 60s^2 + 44s + 48$

s^5	1	45	44
s^4	12	60	48
s^3	40	40	0
s^2	48	48	
s^1	0	0	

As complete row becomes zero we will form an auxiliary equation.

$$A(s) = 48s^2 + 48$$

$$A'(s) = 96s + 0$$

Replacing zeroth row with $A'(s)$

s^5	1	45	44
s^4	12	60	48
s^3	40	40	0
s^2	48	48	
s^1	96	0	
s^0	48		

As all the elements in the 1st columns are positive given f^n is a Hurwitz polynomial.

Q.1(b) Draw dual of the following :

[5]

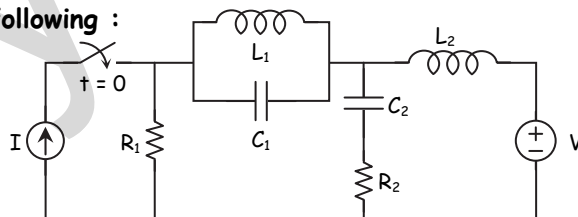

(A)

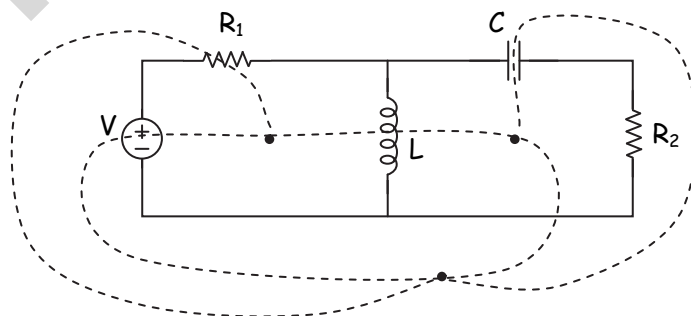

So dual network is given by

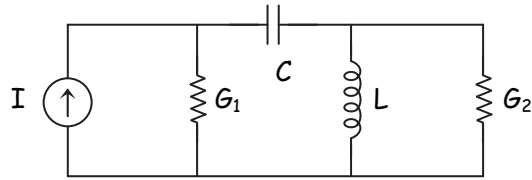

Q.1(c) Determine the short circuit admittance parameters of the network [5]
shown :

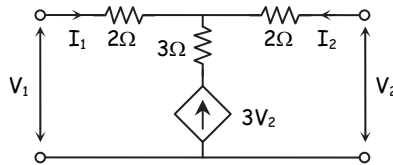

(A)

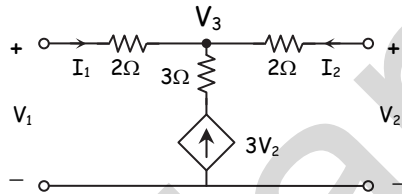

Apply KCL at V_3

$$\frac{V_3 - V_1}{2} + \frac{V_3 - V_2}{2} = 3V_2$$

$$V_3 \left(\frac{1}{2} + \frac{1}{2} \right) = 3V_2 + \frac{V_2}{2} + \frac{V_1}{2}$$

$$V_3 = 0.5 V_1 + 3.5 V_2 \quad \dots(1)$$

Apply KCL at V_1

$$I_1 = \frac{V_1 - V_3}{2}$$

$$I_1 = \frac{V_1}{2} = \frac{1}{2} (0.5V_1 + 3.5V_2)$$

$$I_1 = V_1 (0.25) - V_2 (1.75)$$

Comparing with $I_1 = y_{11}V_1 + y_{12} V_2$

$$y_{11} = 0.25 \text{ } \Omega^{-1} \quad y_{12} = -1.75 \text{ } \Omega^{-1}$$

Apply KCL at V_2

$$I_2 = \frac{V_2 - V_3}{2}$$

$$I_2 = \frac{V_2}{2} - \frac{1}{2} (0.5V_1 + 3.5V_2)$$

$$I_2 = -0.25 V_1 - 1.25 V_2$$

$$y_{21} = -0.25 \text{ } \Omega^{-1}, \quad y_{22} = -1.25 \text{ } \Omega^{-1}$$

Q.1(d) State and prove final value theorem of Laplace transform.

[5]

(A) If $L\{f(t)\} = F(s)$ then $\lim_{t \rightarrow \infty} f(t) = \lim_{s \rightarrow 0} sF(s)$

Proof : We know that

$$L\{f'(t)\} = sF(s) - f(0)$$

$$sF(s) = L\{f'(t)\} + f(0)$$

$$sF(s) = \lim_{s \rightarrow 0} \int_0^{\infty} f'(t)e^{-st} dt + f(0)$$

$$= \int_0^{\infty} \lim_{s \rightarrow 0} [f'(t)e^{-st}] dt + f(0)$$

$$= \int_0^{\infty} f'(t) dt + f(0)$$

$$= [f(t)]_0^{\infty} + f(0)$$

$$= \lim_{t \rightarrow \infty} f(t) - f(0) + f(0)$$

$$= \lim_{t \rightarrow \infty} f(t)$$

Q.2(a) The network shown in figure, a steady state is reached with the switch open. At $t = 0$, the switch is closed. Determine $V_c(0^-)$, $i_1(0^+)$, $i_2(0^+)$, $\frac{di_1}{dt}(0^+)$ and $\frac{di_2}{dt}(0^+)$. [10]

$i_1(0^+)$, $i_2(0^+)$, $\frac{di_1}{dt}(0^+)$ and $\frac{di_2}{dt}(0^+)$.

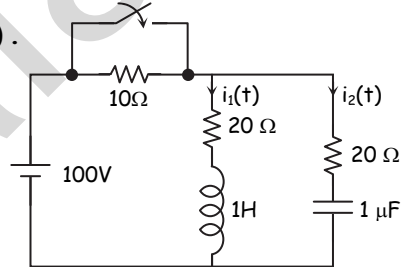

(A) Step 1: At $t = 0^-$, switch is open

$$i_2(0^-) = 0$$

finding $i_1(0^-)$

$$100 - 10i_1 - 20i_1 = 0$$

$$100 = 30i_1$$

$$\therefore i_1 = \frac{100}{30} = \frac{10}{3} \text{ A}$$

$$\therefore i_1(0^-) = \frac{10}{3} \text{ A}$$

$$V_c(0^-) = 20 \times i_1(0^-) = 20 \times \frac{10}{3}$$

$$V_c(0^-) = \frac{200}{3} \text{ V}$$

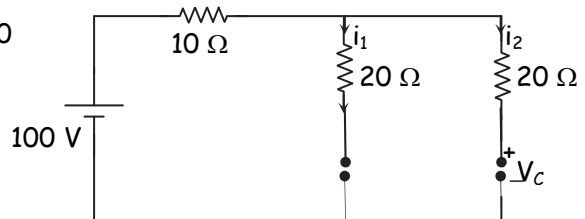

Step 2: At $t = 0^+$

$$i_1(0^+) = \frac{10}{3} \text{ A}$$

Apply KVL to the outer loop

$$100 - 20i_2 - \frac{200}{3} = 0$$

$$20 i_2 = 100 - \frac{200}{3}$$

$$i_2(0^+) = 1.67 \text{ A}$$

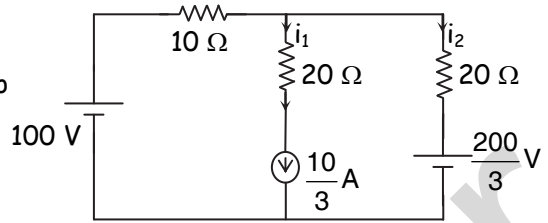

Step 3: At $t > 0$

Apply KVL to loop (1)

$$100 - 20 i_1 - \frac{di_1}{dt} = 0$$

$$\frac{di_1}{dt} = 100 - 20 i_1(0^+)$$

$$= 100 - \frac{20 \times 10}{3}$$

$$\frac{di_1}{dt} = 33.33 \text{ A/s}$$

Apply KVL to outer loop

$$100 - 20 i_2 - \frac{1}{10^{-6}} \int i_2 dt = 0$$

Differentiate w.r.t. t

$$0 - 20 \frac{di_2}{dt} - 10^6 i_2 = 0$$

$$-20 \frac{di_2(0^+)}{dt} = 10^6 i_2(0^+)$$

$$\frac{di_2}{dt} = \frac{-10^6(1.67)}{20}$$

$$\frac{di_2}{dt} = -83500 \text{ A/s}$$

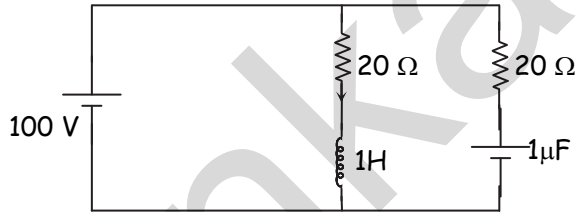

Q.2(b) Find the network functions $\frac{V_1}{I_1}$, $\frac{V_2}{I_1}$, $\frac{V_2}{V_1}$ for the network shown : [5]

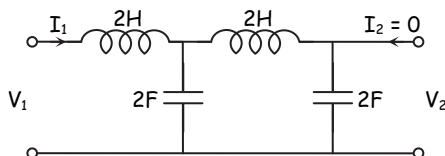

(A) Let $V_2 = 1$

$$\begin{aligned} I_b &= V_2 \times 2S \\ V_a &= V_2 + I_b \cdot 2S \\ &= 1 + 2S \cdot 2S \end{aligned}$$

$$\begin{aligned} V_a &= 1 + 4S^2 \\ I_a &= V_a \cdot 2S \\ &= (1 + 4S^2)2S \end{aligned}$$

$$\begin{aligned} I_a &= 2S + 8S^3 \\ I_1 &= I_a + I_b \\ &= 2S + 8S^3 + 2S \end{aligned}$$

$$\begin{aligned} I_1 &= 8S^3 + 4S \\ V_1 &= V_a + I_1 \cdot 2S \\ &= 1 + 4S^2 + (8S^3 + 4S)2S \\ &= 1 + 4S^2 + 16S^4 + 8S^2 \end{aligned}$$

$$V_1 = 16S^4 + 12S^2 + 1$$

$$\frac{V_1}{I_1} = \frac{16S^4 + 12S^2 + 1}{8S^3 + 4S}$$

$$\frac{V_2}{I_1} = \frac{1}{8S^3 + 4S} \quad \& \quad \frac{V_2}{V_1} = \frac{1}{16S^4 + 12S^2 + 1}$$

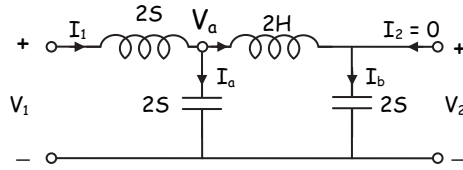

Q.2(c) In the circuit shown in figure, find V_x .

[5]

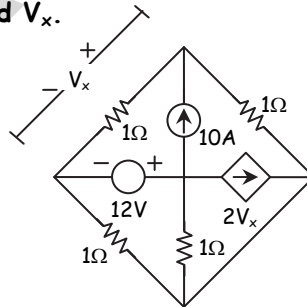

(A)

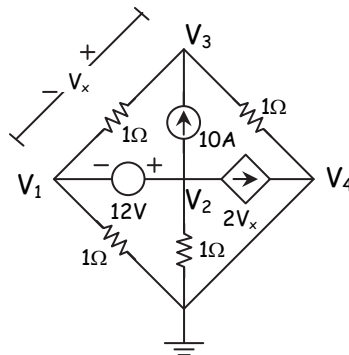

$$V_4 = 0 \text{ V}$$

$$V_x = V_1 - V_3 \quad \dots(1)$$

Relation between V_1 & V_2

$$V_2 - V_1 = 12$$

$$-V_1 + V_2 + 0V_3 = 12 \quad \dots(2)$$

Supernode equation

$$\frac{V_1 - V_3}{1} + \frac{V_1}{1} + \frac{V_2}{1} + 10 + 2V_x = 0$$

$$V_1 - V_3 + V_1 + V_2 + 10 + 2(V_1 - V_3) = 0 \quad \dots(\text{from 1})$$

$$4V_1 + V_2 - 3V_3 = -10 \quad \dots(3)$$

KCL to V_3

$$\frac{V_3 - V_1}{1} + \frac{V_3}{1} = 10$$

$$-V_1 + 0V_2 + 2V_3 = 10 \quad \dots(4)$$

Solving (2), (3) & (4)

$$V_1 = -2 \text{ V}$$

$$V_2 = 10 \text{ V}$$

$$V_3 = 4 \text{ V}$$

$$V_x = V_1 - V_3$$

$$V_x = -2 - 4$$

$$V_x = -6 \text{ V}$$

Q.3(a) Find the voltage across 5Ω resistor in the network shown below. [8]

If $K = 0.8$ is coefficient of coupling.

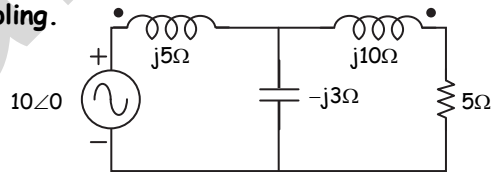

(A) For a magnetically coupled circuit,

$$M = K\sqrt{5(10)}$$

$$X_m = K\sqrt{X_{L_1} X_{L_2}} = 0.8\sqrt{5(10)} = 5.66 \Omega$$

The equivalent circuit in terms of dependent sources can be drawn as

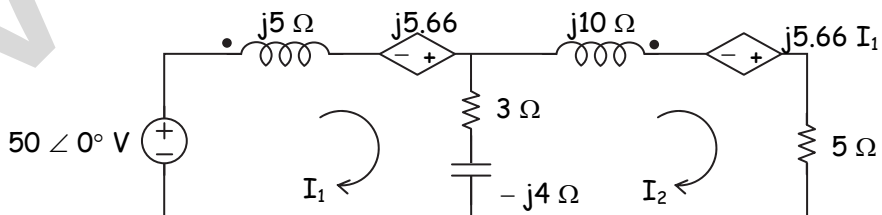

Applying KVL to Mesh 1,

$$50 \angle 0^\circ - j5I_1 - 3(I_1 - I_2) + j4(I_1 - I_2) + j5.66I_2 = 0$$

$$50 \angle 0^\circ = (3 + j1)I_1 - (3 + j1.66)I_2 \quad \dots (1)$$

$$(3 + j1)I_2 + (-3 - j1.66)I_2 = 50 \angle 0^\circ$$

Applying KVL to Mesh 2,

$$j4(I_2 - I_1) - 3(I_2 - I_1) - j10I_2 + j5.66I_1 - 5I_2 = 0$$

$$j4I_2 - j4I_1 - 3I_2 + 3I_1 - j10I_2 + j5.66I_1 - 5I_2 = 0$$

$$-j4I_2 + j4I_1 + 3I_2 - 3I_1 + j10I_2 - j5.66I_1 + 5I_2 = 0$$

$$(-3 - j1.66)I_1 + (8 + j6)I_2 = 0 \quad \dots (2)$$

By Cramer's rule,

$$I_2 = \frac{\begin{vmatrix} 3 + j1 & 50 \angle 0^\circ \\ -3 - j1.66 & 0 \end{vmatrix}}{\begin{vmatrix} 3 + j1 & -3 - j1.66 \\ -3 - j1.66 & 8 + j6 \end{vmatrix}} = 8.62 \angle -24.79^\circ \text{ A}$$

$$V = 5I_2 = 5(8.62 \angle -24.79^\circ) = 43.1 \angle -24.79^\circ \text{ V}$$

Q.3(b) Check the positive real function :

[8]

(i) $F(s) = \frac{s^2 + 6s + 5}{s^2 + 9s + 14}$ (ii) $F(s) = \frac{s^3 + 6s^2 + 7s + 3}{s^2 + 2s + 1}$

(A) (i) $F(s) = \frac{s^2 + 6s + 5}{s^2 + 9s + 14}$

Step 1 : Let $F(s) = \frac{N(s)}{D(s)} = \frac{s^2 + 6s + 5}{s^2 + 9s + 14}$

$$F(s) = \frac{(s+5)(s+1)}{(s+7)(s+2)}$$

The function $f(s)$ has poles at $s = -7$ & $s = -2$ & zeros at $s = -5$ and $s = -1$

\therefore All the poles & zeros are in the left half of s -plane.

Step 2 : As there is no pole on jw axis, the residue test is not carried out.

Step 3 : Even part of $N(s) = m_1 = s^2 + 5$

Odd part of $N(s) = n_1 = 6s$

Even part of $D(s) = m_2 = s^2 + 14$

Odd part of $D(s) = n_2 = 9s$

$$A(w^2) = m_1m_2 - n_1n_2$$

$$= (s^2 + 5)(s^2 + 14) - (6s)(9s) \Big|_{s=jw}$$

$$= s^4 - 35s^2 + 70 \Big|_{s=jw}$$

$\therefore A(w^2) = w^4 + 35w^2 + 70$

$A(w^2)$ is positive for all $w \geq 0$

As all the three conditions are satisfied, the function is a positive real function.

$$(ii) F(s) = \frac{s^3 + 6s^2 + 7s + 3}{s^2 + 2s + 1}$$

Step 1 : Let $F(s) = \frac{N(s)}{D(s)} = \frac{s^3 + 6s^2 + 7s + 3}{s^2 + 2s + 1}$

$$F(s) = \frac{s^3 + 6s^2 + 7s + 3}{(s+1)^2}$$

From above both the poles are lying at $s = -1$

Now we will check for $N(s)$

$$N(s) = s^3 + 6s^2 + 7s + 3$$

The Routh array of $N(s)$ is given by

s^3	1	7
s^2	6	3
s^1	$\frac{39}{6}$	0
s^0	3	

As all elements in 1st column are +ve, $N(s)$ is Hurwitz polynomial.

∴ 1st condition is satisfied.

Step 2 : As there is no pole on $j\omega$ axis, residue test need not to be carried out.

Step 3 : Even part of $N(s) = m_1 = 6s^2 + 3$

$$\text{Odd part of } N(s) = n_1 = s^3 + 7s$$

$$\text{Even part of } D(s) = m_2 = s^2 + 1$$

$$\text{Odd part of } D(s) = n_2 = 2s$$

$$\begin{aligned} A(w^2) &= m_1 m_2 - n_1 n_2 \\ &= (6s^2 + 3)(s^2 + 1) - (s^3 + 7s)(2s) \Big|_{s=jw} \\ &= 4s^4 - 5s^2 + 3 \Big|_{s=jw} \end{aligned}$$

$$A(w^2) = 4w^4 + 5w^2 + 3$$

∴ We can say that $A(w^2)$ is positive for all $w \geq 0$

As all three conditions are satisfied, function $f(s)$ is a positive real function.

Q.3(c) List the types of damping in series R-L-C circuit and mention the condition for each damping. [4]

(A)

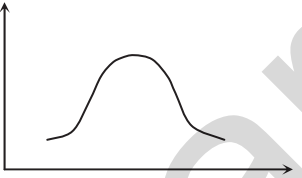
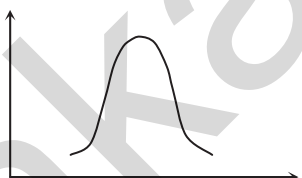
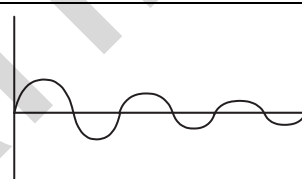
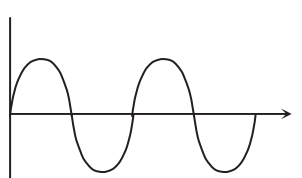
	Nature of Roots	System	Response
1.	Negative unequal	Real $k_1 e^{p_1 t} + k_2 e^{p_2 t}$	
2.	Negative Real equal	Critically damped $k_1 e^{pt} + k_2 t e^{pt}$	
3.	Complex conjugate	Underdamped $e^{-\alpha t} [k_1 \cos \omega t + k_2 \sin \omega t]$	
4.	Conjugate imaginary	Oscillatory $k_1 \cos \omega t + k_2 \sin \omega t$	

where $\alpha = \frac{R}{2L}$ and $\omega_0 = \frac{1}{\sqrt{LC}}$

Q.4(a) For the network shown, determine the current $i(t)$ when the switch is closed at $t = 0$ with zero initial conditions. [8]

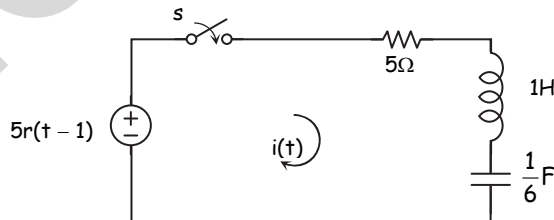

(A) Step 1: At $t = 0^-$, switch is open

$$i(0^-) = 0 \text{ A}$$

$$V_c(0^-) = 0 \text{ V}$$

Step 2 : At $t > 0$, switch is closed.

Applying KVL

$$5 \frac{e^{-s}}{s^2} - 5i(s) - s i(s) - \frac{6}{s} i(s) = 0$$

$$\frac{5e^{-s}}{s^2} = i(s) \left(5 + s + \frac{6}{s} \right)$$

$$\frac{5e^{-s}}{s^2} = \frac{5s + s^2 + 6}{s} i(s)$$

$$(s^2 + 5s + 6) i(s) = \frac{5e^{-s}}{s}$$

$$i(s) = \frac{5e^{-s}}{s(s^2 + 5s + 6)}$$

$$i(s) = \frac{5e^{-s}}{s(s+3)(s+2)}$$

Let $i_1(s) = \frac{1}{s(s+3)(s+2)} = \frac{A}{s} + \frac{B}{s+3} + \frac{C}{s+2}$

$$1 = A(s+3)(s+2) + B s(s+2) + C s(s+3)$$

$$A = \frac{1}{6}, \quad B = \frac{1}{3}, \quad C = -\frac{1}{2}$$

$$i(C) = 5e^{-s} \times i_1(s)$$

$$= 5e^{-s} \left[\frac{1}{6s} + \frac{1}{3(s+3)} - \frac{1}{2(s+2)} \right]$$

$$i(s) = \frac{5e^{-s}}{6s} + \frac{5e^{-s}}{3(s+3)} - \frac{5e^{-s}}{2(s+2)}$$

Taking inverse laplace transform

$$i(t) = \frac{5}{6} u(t-1) + \frac{5}{3} e^{-3(t-1)} u(t-1) - \frac{5}{2} e^{-2(t-1)} u(t-1)$$

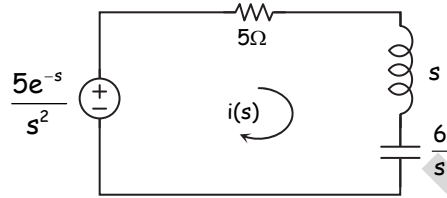

Q.4(b) In the given network switch is closed at $t = 0$. Solve for V , $\frac{dV}{dt}$, [8]

$$\frac{d^2V}{dt^2} \text{ at } t = 0^+$$

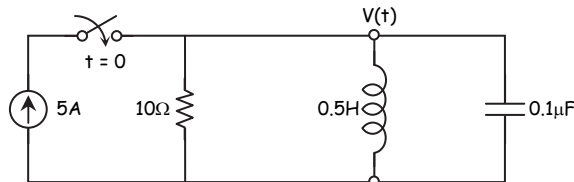

(A) Step 1: At $t = 0^-$, switch is open.

$$i_L(0^-) = 0 \text{ A}$$

$$V_C(0^-) = 0 \text{ V} \text{ \& } V(0^-) = 0 \text{ V}$$

Step 2: At $t = 0^+$, switch is closed.

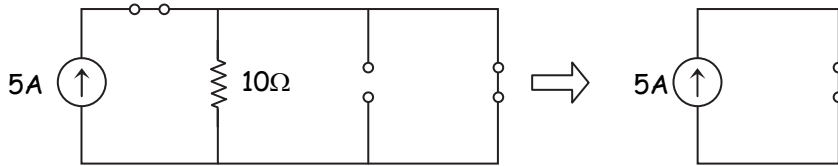

$$i_L(0^+) = 0A$$

$$V_1(0^+) = 0V, \quad V(0^+) = 0V$$

Step 3: At $t > 0$

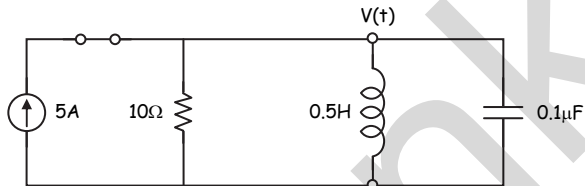

Applying KCL to V

$$\frac{V}{10} + \frac{1}{0.5} \int V dt + 0.1 \times 10^{-6} \frac{dV}{dt} = 5 \quad \dots(1)$$

At $t = 0^+$

$$\frac{V(0^+)}{10} + 0 + 0.1 \times 10^{-6} \frac{dV}{dt}(0^+) = 5$$

$$0.1 \times 10^{-6} \frac{dV}{dt}(0^+) = 5 - 0$$

$$\frac{dV}{dt}(0^+) = \frac{5}{0.1 \times 10^{-6}}$$

$$\frac{dV}{dt}(0^+) = 50 \times 10^6 \text{ v/s}$$

Diff. equation (1) w.r.t. t

$$\frac{dV}{10dt} + \frac{1}{0.5} V(0^+) + 0.1 \times 10^{-6} \frac{d^2V}{dt^2} = 0$$

$$0.1 \times 10^{-6} \frac{d^2V}{dt^2} = \frac{-dV}{10dt}$$

$$\frac{d^2V}{dt^2} = -\frac{50 \times 10^6}{10 \times 0.1 \times 10^{-6}}$$

$$\frac{d^2V}{dt^2} = -50 \times 10^{12} \text{ V/s}^2$$

Q.4(c) Obtain pole-zero plot for $\frac{I_2}{I_1}$.

[4]

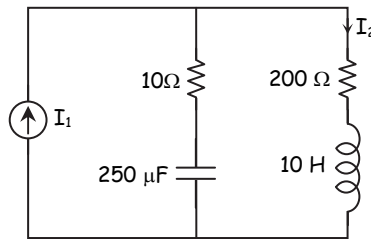

(A) By C.D.R.

$$I_2 = \frac{\frac{4000}{S} + 10}{\frac{4000}{S} + 10 + 200 + 10S} \times I_1$$

$$\frac{I_2}{I_1} = \frac{4000 + 10S}{4000 + 10S + 200S + 10S^2}$$

$$\frac{I_2}{I_1} = \frac{4000 + 10S}{10S^2 + 210S + 4000}$$

$$\frac{I_2}{I_1} = \frac{10(S + 400)}{10(S^2 + 21S + 400)}$$

$$\frac{I_2}{I_1} = \frac{S + 400}{S^2 + 21S + 400}$$

$$Z_1 = -400$$

$$P_1 = -10.5 + 17.02j$$

$$P_2 = -10.5 - 17.02j$$

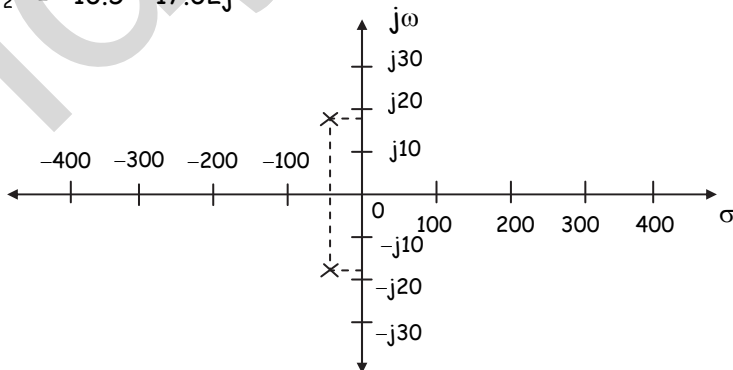
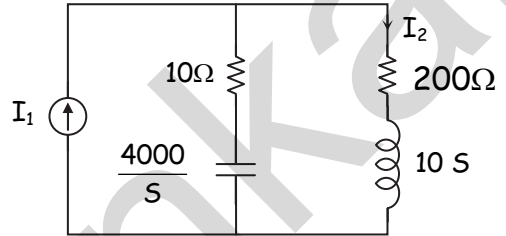

Q.5(a) Synthesize the driving point function using Foster-I and Foster-II [10]

$$\text{form : } Z(s) = \frac{2(s^2 + 1)(s^2 + 9)}{s(s^2 + 4)}$$

(A) Foster – I form :

A degree of numerator is greater than degree of denominator, division is first carried out.

$$Z(s) = \frac{4(s^2 + 1)(s^2 + 9)}{s(s^2 + 4)} = \frac{4s^4 + 40s^2 + 36}{s^3 + 4s}$$

$$\begin{array}{r} 4s \\ s^3 + 4s \overline{) 4s^4 + 40s^2 + 36} \\ \underline{4s^4 + 16s^2} \\ 24s^2 + 36 \end{array}$$

$$\therefore Z(s) = \text{Quotient} + \frac{\text{Remainder}}{\text{Diviser}} = 4s + \frac{24s^2 + 36}{s^3 + 4s} = 4s + \frac{24s^2 + 36}{s(s^2 + 4)}$$

By partial fraction expansion

$$Z(s) = 4s + \frac{k_0}{s} + \frac{2k_1s}{s^2 + 4}$$

$$k_0 = sz(s) \Big|_{s=0} = \frac{4(1)(9)}{4} = 9$$

$$k_1 = \frac{(s^2 + 4)z(s)}{2s} \Big|_{s^2=-4} = \frac{4(-4+1)(-4+9)}{2(-4)} = \frac{15}{2}$$

$$Z(s) = 4s + \frac{9}{s} + \frac{15s}{s^2 + 4}$$

1st term $\Rightarrow 4s \Rightarrow$ inductor of 4H

2nd term $\Rightarrow \frac{9}{s} \Rightarrow$ capacitor of $\frac{1}{9}$ F

3rd term \Rightarrow parallel LC network

For parallel LC network

$$Z_{LC}(s) = \frac{\left(\frac{1}{C}\right)_s}{s^2 + \frac{1}{LC}}$$

Comparing the terms

$$\therefore C = \frac{1}{15}\text{F and } L = \frac{15}{4}\text{H}$$

∴ Corresponding network is as follows.

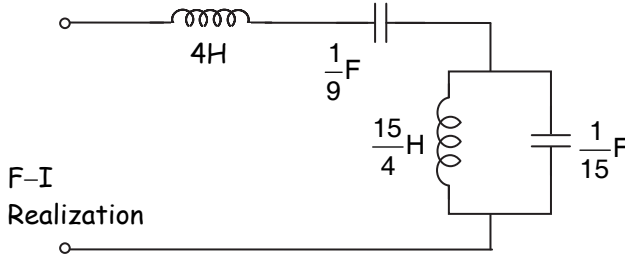

Foster II form :

It is obtain by partial fraction expansion of admittance function

$$Y(s) = \frac{s(s^2 + 4)}{4(s^2 + 1)(s^2 + 9)}$$

By partial fraction expansion

$$Y(s) = \frac{2k_1 s}{s^2 + 1} + \frac{2k_2 s}{s^2 + 9}$$

$$k_1 = \frac{(s^2 + 1)}{2s} Y(s) \Big|_{s^2 = -1} = \frac{(-1 + 4)}{8(-1 + 9)} = \frac{3}{64}$$

$$k_2 = \frac{s^2 + 9}{2s} Y(s) \Big|_{s^2 = -9} = \frac{(-9 + 4)}{8(-9 + 1)} = \frac{5}{64}$$

$$Y(s) = \frac{\left(\frac{3}{32}\right)s}{s^2 + 1} + \frac{\left(\frac{5}{32}\right)s}{s^2 + 9}$$

Above two terms presents admittance of series LC network for series LC

$$\text{network} \Rightarrow Y_{LC}(s) = \frac{\left(\frac{1}{L}\right)s}{s^2 + \frac{1}{LC}}$$

∴ By comparison

$$L_1 = \frac{3L}{3} \text{H} \quad C_1 = \frac{3}{32} \text{F}$$

$$L_2 = \frac{32}{5} \text{H} \quad C_2 = \frac{5}{288} \text{F}$$

Corresponding network is as shown.

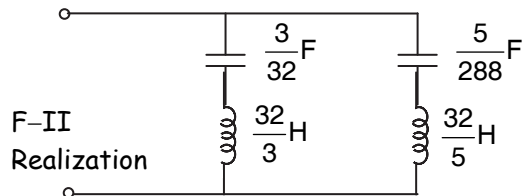

Q.5(b) Obtain hybrid parameter of the inter-connected network.

[10]

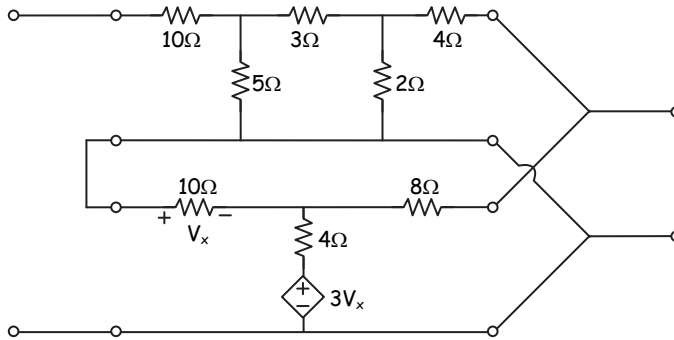

(A) Separate the two networks

1st network

$$V_x = 10 I_1$$

Apply KVL to loop of I_1

$$V_1 - 10I_1 - 4(I_1 + I_2) - 3V_x = 0$$

$$V_1 = 10 I_1 + 4(I_1 + I_2) + 3(10I_1)$$

$$V_1 = 10I_1 + 4I_1 + 4I_2 + 30I_1$$

$$V_1 = 44I_1 + 4I_2$$

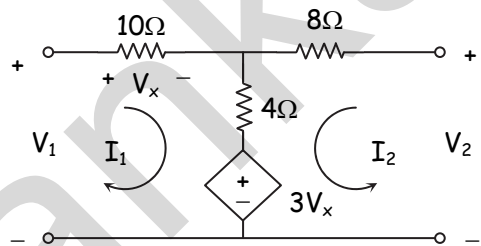

Comparing with $V_1 = z_{11} I_1 + z_{12} I_2$

$$\therefore z_{11} = 44\Omega \quad z_{12} = 4\Omega$$

Apply KVL to loop of I_2

$$V_2 - 8I_2 - 4(I_2 + I_1) - 3V_x = 0$$

$$V_2 = 8I_2 + 4(I_2 + I_1) + 3(10I_1)$$

$$V_2 = 34I_1 + 12I_2$$

Comparing with

$$V_2 = z_{21} I_1 + z_{22} I_2$$

$$\therefore z_{21} = 34 \Omega \quad z_{22} = 12\Omega$$

$$\Delta Z = z_{11} z_{22} - z_{21} z_{12} = 44 \times 12 - 34 \times 4$$

$$\Delta Z = 392$$

Now finding h-parameters from Z-parameter

$$h'_{11} = \frac{\Delta Z}{z_{22}} = \frac{392}{12} = 32.66$$

$$h''_{12} = \frac{z_{12}}{z_{22}} = \frac{4}{12} = 0.333$$

$$h'_{21} = \frac{-z_{21}}{z_{22}} = \frac{-34}{12} = -2.833$$

$$h'_{22} = \frac{1}{z_{22}} = \frac{1}{12} = 0.0833$$

$$\therefore \begin{bmatrix} h'_{11} & h'_{12} \\ h'_{21} & h'_{22} \end{bmatrix} = \begin{bmatrix} 32.66 & 0.333 \\ -2.833 & 0.0833 \end{bmatrix}$$

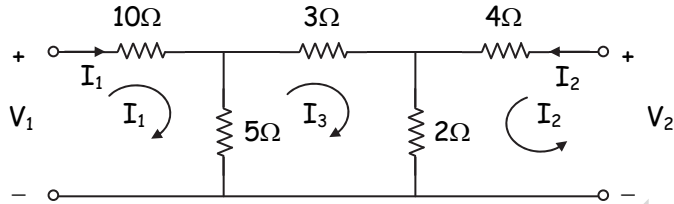

Apply KVL to I_3

$$-5(I_3 - I_1) - 3I_3 - 2(I_3 + I_2) = 0$$

$$-10I_3 + 5I_1 - 2I_2 = 0$$

$$I_3 = \frac{-5I_1 + 2I_2}{-10}$$

$$I_3 = 0.5 I_1 - 0.2 I_2 \quad \dots(1)$$

Apply KVL to I_1

$$V_1 - 10I_1 - 5(I_1 - I_3) = 0$$

$$V_1 = 10I_1 + 5I_1 - 5(0.5I_1 - 0.2I_2)$$

$$V_1 = 12.5I_1 + I_2$$

$$\therefore Z_{11} = 12.5\Omega \text{ \& } Z_{12} = 1\Omega$$

Apply KVL to I_2

$$V_2 - 4I_2 - 2(I_2 + I_3) = 0$$

$$V_2 = 4I_2 + 2I_2 + 2(0.5I_1 - 0.2I_2)$$

$$V_2 = I_1 + 5.6 I_2$$

$$\therefore Z_{21} = 1\Omega \quad Z_{22} = 5.6 \Omega$$

$$\Delta z = Z_{11} Z_{22} - Z_{12} Z_{21} = 12.5 \times 5.6 - 1 \times 1 = 69$$

Converting Z to h parameters

$$\begin{bmatrix} h''_{11} & h''_{12} \\ h''_{21} & h''_{22} \end{bmatrix} = \begin{bmatrix} 12.32 & 0.178 \\ -0.178 & 0.178 \end{bmatrix}$$

h - parameter of the interconnected network is given by,

$$\begin{bmatrix} h_{11} & h_{12} \\ h_{21} & h_{22} \end{bmatrix} = \begin{bmatrix} h''_{11} + h''_{11} & h''_{12} + h''_{12} \\ h''_{21} + h''_{21} & h''_{22} + h''_{22} \end{bmatrix}$$

$$\begin{bmatrix} h_{11} & h_{12} \\ h_{21} & h_{22} \end{bmatrix} = \begin{bmatrix} 44.98 & 0.511 \\ -3.011 & 0.261 \end{bmatrix}$$

Q.6(a) For the network shown below, draw a graph of network. Select a tree and obtain :

- (i) Reduced incidence matrix
- (ii) f-cut set matrix
- (iii) f-tie set matrix

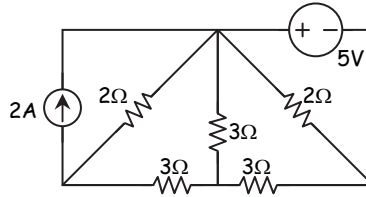

(A) (i) Incidence matrix

No. of Nodes	No. of Branches					
	1	2	3	4	5	6
1	-1	1	0	1	0	0
2	0	0	0	-1	1	1
3	0	-1	1	0	-1	0
4	1	0	-1	0	0	-1

So the incidence matrix is

$$A_a = \begin{bmatrix} -1 & 1 & 0 & 1 & 0 & 0 \\ 0 & 0 & 0 & -1 & 1 & 1 \\ 0 & -1 & 1 & 0 & -1 & 0 \\ 1 & 0 & -1 & 0 & 0 & -1 \end{bmatrix}$$

(ii) f-tieset matrix
Selecting a tree

No. of f-cutset	No. of Branches					
	1	2	3	4	5	6
1	1	0	0	1	0	1
2	0	1	0	-1	-1	0
3	0	0	1	0	1	-1

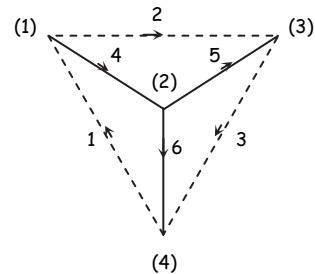

∴ The f-tieset matrix is

$$B = \begin{bmatrix} 1 & 0 & 0 & 1 & 0 & 1 \\ 0 & 1 & 0 & -1 & -1 & 0 \\ 0 & 0 & 1 & 0 & 1 & -1 \end{bmatrix}$$

(iii) f-cutset matrix

f-cutset	No. of Branches					
	1	2	3	4	5	6
4	-1	1	0	1	0	0
5	0	1	-1	0	1	0
6	-1	0	1	0	0	1

So the f-cutset matrix is

$$Q = \begin{bmatrix} -1 & 1 & 0 & 1 & 0 & 0 \\ 0 & 1 & -1 & 0 & 1 & 0 \\ -1 & 0 & 1 & 0 & 0 & 1 \end{bmatrix}$$

Q.6(b) Find V_x using superposition theorem.

[10]

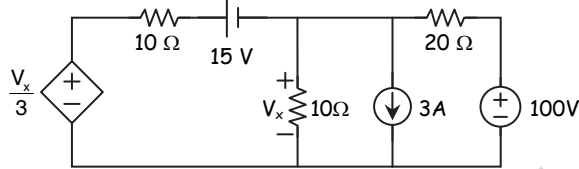

(A) Step (1) 15V is active

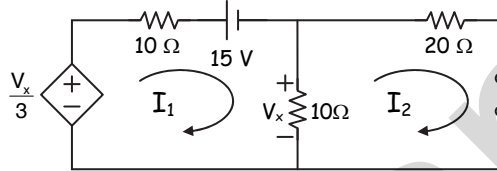

Apply KVL to I_1

$$\frac{V_x}{3} - 10I_1 - 15 - 10(I_1 - I_2) = 0$$

$$V_x = 10(I_1 - I_2)$$

$$\frac{10(I_1 - I_2)}{3} - 10I_1 - 15 - 10(I_1 - I_2) = 0$$

$$I_1 \left(\frac{10}{3} - 20 \right) + I_2 \left(-\frac{10}{3} + 10 \right) = 15 \quad \dots(1)$$

Apply KVL to I_2

$$-10(I_2 - I_1) - 20I_2 = 0$$

$$10I_1 - 30I_2 = 0 \quad \dots(2)$$

Solving (1) & (2)

$$I_1 = -1.038, \quad I_2 = -0.346$$

$$V_x = 10(I_1 - I_2) \\ = 10(-1.038 + 0.346)$$

$$V_x = -6.92 \text{ V}$$

Step (2) 3A is active

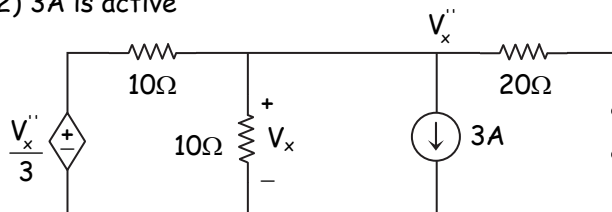

Apply KCL to V_x''

$$\frac{V_x'' - \frac{V_x''}{3}}{10} + \frac{V_x''}{10} + 3 + \frac{V_x''}{20} = 0$$

$$V_x'' \left(\frac{1}{10} - \frac{1}{30} + \frac{1}{10} + \frac{1}{20} \right) = -3$$

$$V_x'' = -13.846 \text{ V}$$

Step (3) 100V is active

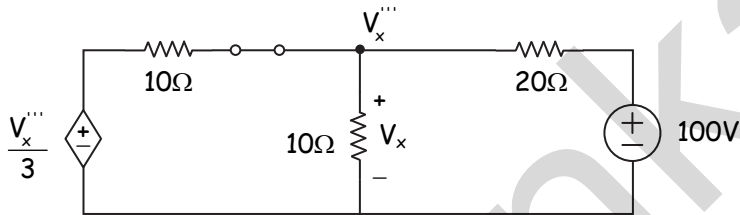

$$\frac{V_x''' - \frac{V_x'''}{3}}{10} + \frac{V_x'''}{10} + \frac{V_x''' - 100}{20} = 0$$

$$V_x''' \left(\frac{1}{10} - \frac{1}{30} + \frac{1}{10} + \frac{1}{20} \right) = 5$$

$$V_x''' = 23.07 \text{ V}$$

Step (4) finding V_x

$$V_x = V_x' + V_x'' + V_x'''$$

$$V_x = -6.92 - 13.846 + 23.07$$

$$V_x = 2.304 \text{ V}$$

□ □ □ □ □